

Performance Improvement and Efficiency Optimization of an Industry through Energy Audit

Barot Vishal Kumar G, Sirish K Patel

Department of Mechanical Engineering, Government Engineering College Valsad, Gujarat, India

Article Info

Article history:

Received 02 April 2016

Received in revised form

20 May 2016

Accepted 28 July 2016

Available online 15 September 2016

Keywords

Energy Audit, Boiler, Chilling System, Pumps, Cooling Tower

Abstract

An Energy Audit is an examination of an energy consuming equipment/system to ensure that energy is being used efficiently. An Energy Audit involves measuring the actual energy used in the plant, comparing it with an estimate of the minimum energy required to undertake the process and establishing technically and economically feasible means to achieve the same. In this paper Energy Audit Of various Utilities like Boiler, chilling system, Pumps, cooling tower has been carried out Also Possible Recommendations has been suggested this will ultimately led the industry into financial saving.

1. Introduction

Energy Audit is important tool to a systematic approach for decision-making in the area of energy management. It tries to balance the total energy inputs with its use, and serves to identify all the energy streams in a facility. It quantifies energy usage according to its discrete functions. Industrial energy audit is an effective tool in defining and pursuing comprehensive energy management program. In any industry, the three top operating expenses are often found to be energy (both electrical and thermal), labour and materials. It is important that the industry should be provided with the right perception of the benefits of the energy audit. These Guidelines are targeted at industrial firm, the energy consuming equipment/systems in particular. [1]

2. Objectives

1. To carry out Energy audit Of various utilities
2. To investigate excess Energy usage Area and Evaluate performance
3. Suggest Recommendations/ways To reduce Energy usage and improve performance
4. Economical Analysis If possible.

3. Energy Audit

Chilling System: In Present Research paper Energy audit of total 2 nos. x 340 TR Cristopia Energy chilling system audit has been carried out.

*Corresponding Author,

E-mail address: sonubrahmbhatt9200@gmail.com

All rights reserved: <http://www.ijari.org>

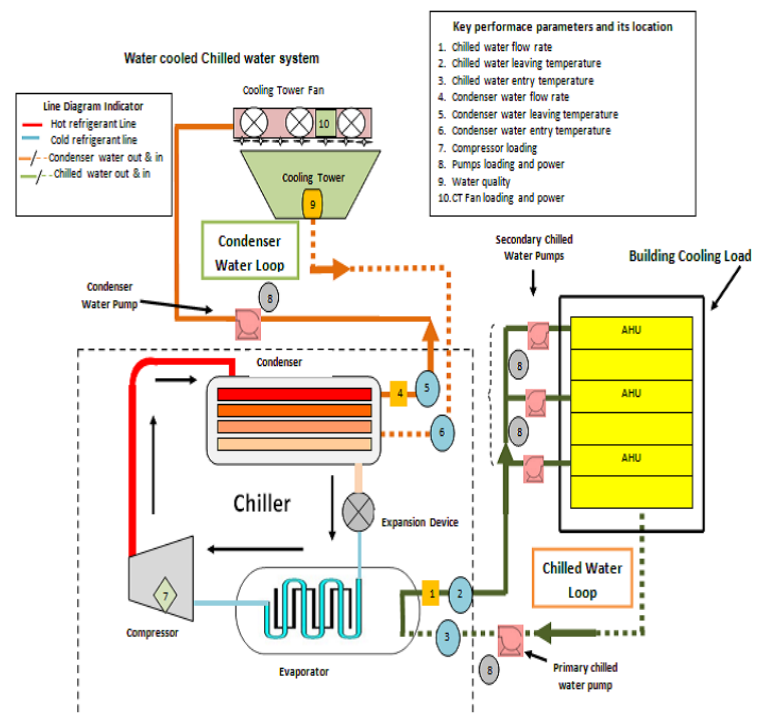

Fig: 1 Typical water cooled chilling system [2]

4. Recommendations

Based on the above it is understood that at present across evaporator pressure drop found on higher side (0.8 Kg/cm²) against design of 0.3 Kg/cm².

This indicates scaling inside the evaporator tubes which also decrease heat transfer and increase power consumption of the compressor.

(A) **Compressor:** Based on the Compressor pressure, present existing gas quantity found lesser in compressor.

This also affects the performance of the chillers. So charge the gas accordingly requirement and maintain sufficient pressure in compressor.

Sometimes due to high Compressors discharge pressure compressor also observed in safe unloading condition. So look into the matter and maintain HP & LP pressure with proper gas filling and improve the chiller performance

It is also beneficial to provide design condenser water to each chiller condenser.

Excess water also reduces the temperature difference.

It is also suggested to charge the gas, and reducing the present specific power consumption norms. It is also suggested to clean the evaporator and condenser tubes

regularly to avoid scaling inside the tubes and avoid back pressure in pumps

(B) Pumps: In Present Research paper Energy audit of Total 3 nos. pumps has been carried out which are used for the chiller-1 & 2 chilled water requirements of chillers. Primary chiller pumps and condenser chiller pumps has been observed.

(C) Cooling Tower:

Here, total 2 nos. cooling towers (one for 340 TR system & one for VAHP) observed in plant for the cooling of the plant return water. In 340 TR system total 2 nos. cooling tower fan observed and for VAHP total 4 nos. cooling tower fan found.



Fig.2: CHW chiller [3]

Table 1: Screw Chiller Evaporator Pressure Drop

Sr. No	Description	Screw Chiller-1		Screw Chiller-2	
		Evaporator-1	Evaporator-2	Evaporator-1	Evaporator-2
1	Evaporator Inlet pressure (Kg/cm ²)	2.8	Valve closed	2.8	2.8
2	Evaporator Outlet pressure (Kg/cm ²)	2		2	2
3	Pressure difference (Kg/cm ²)	0.8		0.8	0.8

Table 2: Screw Chiller condenser Pressure Drop

Sr. No	Description	Screw Chiller-1		Screw Chiller-2	
		Condenser-1	Condenser-2	Condenser-1	Condenser-2
1	Condenser Inlet pressure (Kg/cm ²)	2	Valve closed	2	2
2	Condenser Outlet pressure (Kg/cm ²)	1.8		1.8	1.8
3	Pressure difference (Kg/cm ²)	0.2		0.2	0.2

Table 3: Performance of Chiller-1

Sr. No.	Chiller No.	Rated	Identification	Chilled Water				Compressor	TR	KW/TR
		Capacity		Total Flow	Inlet Temp.	Outlet Temp.	ΔT	Power		
		(TR)		(M3/hr)	(°C)	(°C)	(°C)	(KW)		
1	Chiller-1	340	Water Chiller	107	10.4	7.1	3.3	75.8	116.8	0.65

Table 4: Performance Of chiller-2

Sr. No.	Chiller No.	Rated	Identification	Chilled Water				Compressor	TR	KW/TR
		Capacity		Flow	Inlet Temp.	Outlet Temp.	ΔT	Power		
		(TR)		(M3/hr)	(°C)	(°C)	(°C)	(KW)		
1	Chiller-2	340	Water Chiller	258	9.6	6.7	2.9	243	247.4	0.98

Table 5: Savings by maintaining blow down

Sr. No.	Description	Unit	340 TR
1	Rated Kw	KW	255
2	Measured power of only one comp-1*	KW	75.8
3	Opt. Hr/day	HR/DAY	16
4	Annual Operating Day	Day	350
5	Unit cost Rs	RS/KWH	6.5
6	Present total TR Generation*	TR	116.77
7	Present average specific power consumption	KW/TR	0.65
8	Proposed Specific power cons.	KW/TR	0.55
9	Saving in KWH	KWH	11.5765
10	Annual saving possible	Rs.	421384.6
11	Estimated Investment of overhauling	Rs.	250000
12	Simple payback period	MONTHS	7.12
* Power of only one comp at half load condition			

Table 6: Savings in chiller-2

Sr. No.	Description	Unit	340 TR
1	Rated Kw	KW	255
2	Measured total Power*	KW	243.0
3	Opt. Hr/day	HR/DAY	24
4	Annual Operating Day	Day	350
5	Unit cost Rs	Rs./KWH	6.5
6	Present total TR Generation*	TR	247.42
7	Present average specific power consumption	KW/TR	0.98
8	Proposed Specific power cons.	KW/TR	0.66
9	Saving in KWH	KWH	79.7028
10	Annual saving possible	Rs.	4351773
11	Estimated Investment of overhauling	Rs.	250000
12	Simple payback period	MONTHS	0.69
Remarks - * Both chiller circuit in line			

Table7: Performance Evaluation of Primary chiller pump

Sr. No.	Description	Unit	Pump-1	Pump-2
1	Rated HP	HP	25	25
2	Rated Kw	Kw	18.5	18.5
3	Measured Power	Kw	16.4	15
4	Opt. Hr/day	hr/day	24	16
5	Moto Efficiency	%	0.92	0.92
6	Pump Head	mtr.	14	14
7	Existing Flow	m3/hr	201	171
8	Efficiency of pump	%	50.82	47.27

Table 7: Performance Evaluation of Condenser Pump

Sr. No.	Description	Units	Pump-1	Pump-2
1	Rated HP	HP	75	75

2	Rated Kw	Kw	55	55
3	Measured Power	Kw	31.4	33.1
4	Opt. Hr/day	hr/day	24	16
5	Motor Efficiency	%	0.92	0.92
6	Pump Head	mtr.	16	16
7	Existing Flow	m3/hr	311	297
8	Efficiency of pump	%	46.94	42.52

Table 8: Savings In primary chiller pump

Sr. No.	Description	Unit	Pump-1	Pump-2
1	Rated HP	HP	25	25
2	Rated Kw	Kw	18.5	18.5
3	Measured Power	Kw	16.4	15
4	Opt. Hr/day	hr/day	24	16
5	Moto Efficiency	%	0.92	0.92
6	Pump Head	mtr.	14	14
7	Existing Flow	m3/hr	201	171
8	Efficiency of pump	%	50.82	47.27
9	Unit cost	Rs./Kwh	6.5	6.5
10	Annual Operating day	day	350	350
11	Proposed efficiency of pump %	%	0.8	0.8
12	Proposed Head	mtr.	17	17
13	Proposed Flow	m3/hr	205	205
14	Estimated power	Kw	12.9	12.9
15	Power Saving	Kwh	3.5	2.1
16	Annual saving possible	Rs.	190988	76365.2
17	Investment of only one new pump	Rs.	150000	150000
18	Simple payback period	month	9.42	23.57

Table9: Savings In condenser pumps

Sr. No.	Description	Units	Pump-1	Pump-2
1	Rated HP	HP	75	75
2	Rated Kw	Kw	55	55
3	Measured Power	Kw	31.4	33.1
4	Opt. Hr/day	hr/day	24	16
5	Motor Efficiency	%	0.92	0.92
6	Pump Head	mtr.	16	16
7	Existing Flow	m3/hr	311	297
8	Efficiency of pump	%	46.94	42.52
9	Unit cost	Rs./Kwh	6.5	6.5
10	Annual Operating day	Day	350	350
11	Proposed efficiency of pump	%	0.8	0.8
12	Proposed Head	mtr.	20	20
13	Proposed Flow	m3/hr	280	280
14	Estimated power	Kw	20.73	20.73
15	Power Saving	Kwh	10.7	12.4
16	Annual saving possible	Rs.	582465	450190
17	Investment of only one new pump	Rs.	200000	200000
18	Simple payback period	month	4.12	5.33

Table 10: Performance Evaluation of cooling Tower

Sr No.	Parameter	Units	340 TR		VAHP	
			Fan-1	Fan-2	Fan-1	Fan-2
1	Used for		Cooling	Cooling	Cooling	Cooling
2	Cooling water out let temperature	°C	32.3	32.4	32.1	32.2
3	Cooling water Inlet temperature	°C	38	37.8	36.3	36.5
4	Dry bulb temperature	°C	33.9	33.9	33.8	33.9
5	Wet bulb temperature	°C	32.5	31.4	32.4	32.1
6	Range	°C	5.7	5.4	4.2	4.3

7	Approach		5.5	6.4	3.9	4.4
8	Effectiveness	%	50.89	46	52	49

Table 11: Savings in cooling tower by installing VFD on spray pumps

Saving potentiality by Installation of VFD on Spray Pump	
Power consumption of one big spray pump-Avg	109kW
Saving Potentiality – 30%	32.7 kWh
Saving potentiality in kWh/annum	117720 kWh
Saving In amount	Rs. 470880/annum
Simple Payback Period	15 Months

4.2 Recommendations

The present effectiveness of the cooling tower found in the range of 46 to 52 %. This is quite satisfactory. During the field study it is observed that for 340 TR Chiller, plant personal provided separate two nos. CT with fan. For VAHP, total 4 nos. CT fan observed.

During the field study it is understood that in VAHP CT, CT fan-4 working in auto mode and its mainly running with 75 TR VAHP.

During the study, CT fan found continuously running. So we suggest install temperature controller save CT fan power.

Cooling Tower pump is working constantly day and night irrespective of heat load.

It is suggested to put VFD on one spray pump motor which will control flow of water by adjusting speed of pump. Speed may be adjusted as per required set temperature for injection process. Nearly 30% saving is achieved by such controller.

It is suggested to install automatic temperature controller for cooling tower. The controller should be switch o_ the fan when the temperature goes down below the set temperature and switches on when temperature goes above the set temperature (28-30C)

Table 12: Saving in cooling tower by using cooling tower fan controller

Saving Potentiality by Cooling tower fan Controller	
Power Consumption of two CT fans	8.54 kW
Power saving @30% Due to temp controller	2.56 kW
Annual Power saving (150 days/annum*24hours/day)	9216 kWh
Annual Money saving	Rs. 36864
Investment For temperature Controller	Rs. 1000
Simple Payback Period	3.3 Months

(d) Boiler

Here energy audit of two identical boilers has been carried out which burn heavy Fuel oil. The boilers are water tubes unit of Russian design and construction built in 1990. The nominal capacity of each is 5 TPH at 2.8 TPH. Each boiler has an operating mazout flow meter, also are steam flow meters. The boilers are blown down continuously, and they are also blown down manually at frequent duration. There is no separate boiler feed water treatment at the plant. There is no condensate recovery. Although the plant was originally designs for condensate recycle. Contamination problems resulted in its discontinuance. The boilers are balanced draft (FD/ID fans) and are Equipped with economizers.

Table 13: Performance Evaluation of 5 TPH boiler

S No.	Description	Unit	Value
Heat Input			
1	FO Consumption during trial	Kg	8597
2	Calorific value of FO	Kcal/Kg	10142
3	Total heat input	Kcal	87190774
Heat Output			
4	Avg. steam generation	Kg	114100

5	Enthalpy of steam	Kcal/Kg	662.9
6	Enthalpy of boiler feed water	°C	40
7	Heat output in steam (MCpΔT)	Kcal	71072890
8	Efficiency (Heat Output / Heat Input x 100)	%	81.51

Table 14: Performance Evaluation of 2.8 TPH boiler

S No.	Description	Unit	Value
Heat Input			
1	FO Consumption during trial	Kg	301
2	Calorific value of FO	Kcal/Kg	10142
3	Total heat input	Kcal	3052742
Heat Output			
4	Feed water used during trial	KL	3724
5	Enthalpy of steam	Kcal/Kg	661.2
6	Enthalpy of boiler feed water	°C	38
7	Heat output in steam (MCpΔT)	Kcal	2327029
8	Efficiency (Heat Output / Heat Input x 100)	%	76.23

Table 15: Savings by maintaining Blow down

Sr No.	Parameter	Units	Value
1	Boiler water TDS		4000
2	Feed water TDS		100
3	Present make up water quantity	%	60
4	Blow Down required as per the present load	Kg/hr	30
5	Present blow down quantity ((Considering 18 hr/day and quantity based on panel data)	Kg/hr	516
6	Excess blow down qty./Annum	m3/hr	3059.35
7	Cost of makeup water	Rs./yr	45890
8	Total energy wasted in blow down	Kcal/day	699840
9	Present steam cost	Rs./Kg.	3.28
10	Heat loss	Rs./Annum	1294163

11	Estimated investment		Nil
12	Total saving due to excess blow down	Rs./Annum	1340053
13	Simple payback within months		Immediate

Table 16: Savings with installation of Economizer with 5 TPH boilers

Sr. No	Description	Units	Value
1	Avg. Flue gas temperature	°C	210
2	Proposed flue gas temperature	°C	100
3	App. Flue gas quantity		30000
4	Considering spec. heat of flue gas	Kcal/kg	0.24
5	Daily heat recovery	Kcal	792000
6	Equivalent fuel saving	Kg/day	63
7	Annual monetary saving	Rs./Annum	963039
8	Estimated investment for Economizer	Rs.	150000
9	Simple pay back within months	Months	1.87

Table 17: Saving By using Bio-mass Briquette boiler

Sr. No	Description	Unit	Data
1	Existing FO cost	Rs/Kg	43.5
2	GCV of FO	Kcal/Kg	10142
3	Present FO Consumption	Kg/Day	2620
4	Existing Fuel cost	Rs/Day	113970
5	Bio mass Briquette cost	Rs/Kg	5
6	GCV of Briquette	Kcal/kg	3700
7	Equivalent Briquette consumption	Kg/day	7182
8	Proposed fuel cost based on Briquette	Rs/Day	35908
9	Operating days	Day/Annum	350
10	Saving in monetary terms	LacsRs/Annum	273.22
11	Estimated investment of new 5 TPH boilers with accessories, installation, & fittings etc.)	LacsRs/Annum	175
12	Simple payback with in	Months	7.69

4.3 Recommendations:

Here the blow down is According to TDS level so instead of the auto blow down working based on the TDS level it may be working based on timer based. So kindly check and reduce the excess blow down quantity. It will also reduce the FO consumption as well as reduce the boiler loading. Here not much feed water temperature observed. So considering the present continuously blow down in drain and ash steam near underground tank it is suggested recovering ash steam through ash vessel and pre heat the feed water temperature. This shall also be reducing fuel consumption.

It is observed that exhaust flue gas temperature of the boiler found around 200-210 C. This is directly goes to atmosphere without any recovery. So looking to the present operating system in 5 TPH boiler, we suggest to provide Economizer and pre heat the feed water temperature. Based on the present FO cost, steam cost and loading on the boiler, we suggest replacing the existing FO fired boiler with Bio mass Briquette based boiler. By replacing the FO fired boiler with Bio mass briquette as fuel steam cost shall be reduce.

5. Conclusions

Sr.No	Area/Method	Annual Saving in Rs	Investment in Rs	Payback in Month
1	Reducing power consumption of chiller-1	421384.6	250000	7.12
2	Reducing Power consumption of chiler-2	4351773	250000	0.69
3	Reducing Power consumption Of pump-1 (primary)	190988	150000	9.42
4	Reducing power consumption of pump-2 (primary)	76965.2	150000	23.75
5	Reducing power consumption of pump-1 (condenser)	582465	200000	4.12
6	Reducing power consumption of pump-2 (condenser)	450190	200000	5.33
7	Saving potential by installation of VFD on spray pump (cooling tower)	470880	600000	15
8	Saving potential by installing cooling tower fan controller	36864	10000	3.3
9	Saving potential By maintaining Blow down In boiler	1340053	Nil	Immediate
10	Saving potential With installation Of Economizer in boiler	963039	150000	1.87
11	Saving potential By using biomass briquette boiler	273000000	173000000	7.69
	Total	28 2222816	175210700	8 months

References

- [1] Energy Audit Manual, Energy Management Centre Kerala, Department of Power, Government of Kerala. Retrieved from <http://www.keralaenergy.gov.in/EED/SDA/Energy>
- [2] A. Hasan, K. Siren. Performance investigation of plain and finned tube evaporative cooled Heat exchangers [J]. Applied Thermal Engineering, 2003, 23(3):325-340.
- [3] Raphael Wentemipeaning, May 2012, Energy Efficiency and Management in Industries a case study of Ghanas largest industrial area